

City of Elkhorn

**Accessory Structures
Application**

**Attached & Detached Garages,
Pole Barns and Sheds**

City of Elkhorn

Attached & Detached Garages, Pole Barns and Sheds

The following is required for all accessory structures:

1. Building/Zoning Application
 - ✓ Application **must** be filled out completely to insure prompt service
 - ✓ Application **must** include the name, address and license number of all contractors
2. Site plan showing:
 - ✓ Location of all existing structures
 - ✓ The proposed location of accessory structures
 - ✓ Distances between principal structure and proposed accessory structures
 - ✓ Location of any sewer lateral, water lateral wells, septic systems, or leach beds. Approval from the Walworth County Sanitation may be required
 - ✓ Distances from proposed accessory structures to side, rear and street lot lines
 - ✓ The shore yard setback seventy-five (75) feet from the high water elevation mark of any stream creek, lake or pond must be indicated, if applicable
 - ✓ All plans shall be prepared in a recognized engineering or architectural scale and include a north arrow and any abutting streets or roads
3. Accessory structure size and location:
 - ✓ Accessory uses and detached accessory structures are permitted in the rear yard only; they shall not be closer than five (5) feet to the principal structure except when in conformance with local building and fire codes; shall not exceed fifteen (15) feet in height; shall not occupy more than twenty (20) percent of the rear yard area in all districts except the business districts where such uses and structures shall not occupy more than seventy-five (75) percent of the rear yard area; and except RS-1 residential districts where detached accessory structures shall not exceed 775 square feet in size, and shall not be closer than three (3) feet to any lot line nor five (5) feet to an alley line (when in excess of 775 square feet in area, in the RS-1 district see Section 3.4 “Conditional Uses”).
 - ✓ Accessory uses and detached accessory structures on lots and parcels within the shore land jurisdiction of this ordinance shall not extend into the required shore yard unless otherwise specifically permitted by the Shore land Ordinance

Accessory uses and structures are permitted in any district but not until their principal use or structure is present or under construction. Residential accessory uses shall not involve the conduct of any business, trade, or industry except home occupation and professional home offices as defined in the city ordinance. Accessory structures shall not be used as a secondary principal residence.

** It is your responsibility as the applicant to place the permit card on the premises, visible from the street and protected from the weather. Construction Drive and silt fence shall be installed prior to construction.

** Inspection requests need to be called in with 48hrs notice preferred, although same day inspections may be handled. Please see attached sheets for a list of the required inspections and the information needed when requesting an inspection.

City of Elkhorn
Building Inspection & Zoning Departments
Building Inspector
(262) 741-5115
Zoning Administrator
(262) 741-5124

Inspection Requests Information

To schedule an inspection

Call:

(262) 741-5115

Please be ready to provide the following information. Your inspection **CANNOT** be scheduled without this information

- Municipality
- Inspection Address
- Permit Number
- Owner's Name
- Contractor
- Contact Phone Number
- Inspection Type
- Date & Time Ready for Inspection
-

Access for the inspector is required (ex: ladder, lock box, key location, etc.)

** It is your responsibility as the applicant to place the permit card on the premises, visible from the street and protected from the weather. Construction Drive and silt fence shall be installed prior to construction.

** Inspection requests need to be called in with 48hrs notice preferred, although same day inspections may be handled. Please see attached sheets for a list of the required inspections and the information needed when requesting an inspection.

Thank You for your Cooperation!

Inspections Needed Checklist

1. **Sanitary sewer, storm sewer and water lateral:** **BEFORE** backfilling of trench. System should be on test at time of inspection.
2. **Footing forms:** **BEFORE** any concrete is poured, bleeders must be installed eight feet on center.
3. **Foundation wall drain tiles:** **AFTER** 12” of stone is in place on top of tiles and 12” beyond edge of footing.
4. **Building sanitary drain:** **BEFORE** basement floor is poured.
5. **Basement floor:** **BEFORE** basement is poured and **AFTER** vapor barrier is in place. Clean out bleeder ends!!!
6. **Electrical Service:** **BEFORE** electric utility connection, underground pedestal or overhead service. Mark service location on survey.
7. **All roughs (carpentry, electrical, plumbing, HVAC):** **BEFORE** insulating.
 - ✓ These should be called in together whenever possible
 - ✓ At this time, all penetrations should be sealed for inspection
 - ✓ Copy of Truss specs shall be supplied for the inspector at Rough Inspection
8. **Insulation:** **BEFORE** applying any finished materials.
9. **Final Inspection:** **ALL** carpentry, electrical, plumbing HVAC and other mechanical installations **BEFORE** any occupancy will be issued. (Working kitchen, one complete full bathroom, final grade, address sidewalk and driveway if applicable).
10. **Water Meter:** **MUST** be installed prior to occupancy.

Failure to request an inspection is in violation of Local and State Building Code and will be subject to a fine, which will be levied against the property owner.

Certificate of Occupancy: will be issued after a final inspection has been done and the building inspector deems the property suitable for occupancy. The building may not be occupied until a certificate has been issued.

Sample of Scale Plot Plan – Directions

1. List the direction of north on the plot
2. List what the scale is (e.g. 1'=30')
3. Draw all structures existing and proposed on the plan to scale
4. Show location of well and septic
5. Be sure that the setbacks listed on the application are the same as on the plot plan
6. Label all structures
7. Setbacks are the distances from the closest point of a structure to a lot line
8. Show all streets that border the property
9. Setback requirements with a scaled plot plan are one and one half times the normal requirement that would be accepted with a plat of survey. EX: If the zoning requirement setback from the rear yard to the structure is 50 feet, it would be 75 feet if you are using a scaled plot plan. (A plat of survey is a survey done by a Wisconsin licensed surveyor).
10. Show the location of the driveway. This locates the front of the structure for zoning purposes

This is the minimum of information that is required

**WITHOUT THIS INFORMATION YOUR APPLICATION WILL BE DENIED AND
LENGTHEN THE TIME IT TAKES TO ISSUE YOUR PERMIT**

Building Permit – Plot Plan

EXAMPLE:

Date: ____ / ____ / ____
Name of Applicant: _____
Address: _____
Phone Number: _____
Project Description: _____
Present Zoning: _____

Important Required Data:

- A – Lot Stakes Must Be Accessible
- B – Show All Present Existing Buildings or Structures on your Lot
- C – Lot Size and Building Location
- D – Indicate North Direction
- * Dimensions as Per Zoning Ordinance

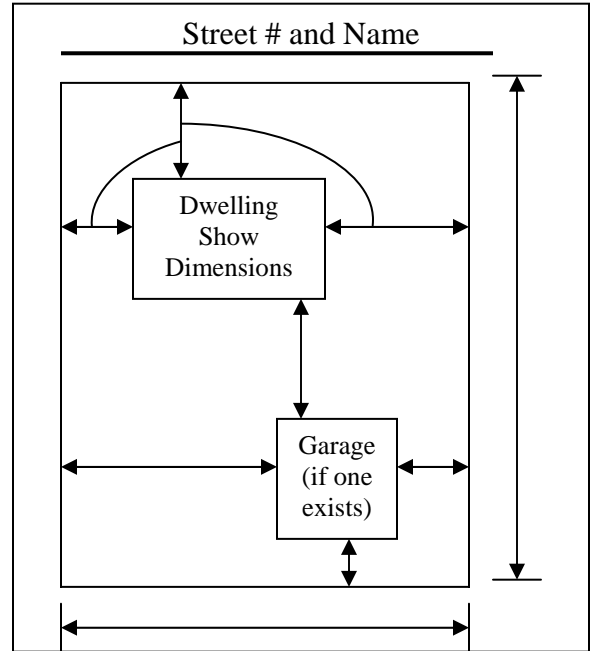

.....
Sketch Your Plot Plan Below – Supply Complete Information – Locate Buildings On Lot & Show All Dimensions To Lot Lines – See Sketch Above For Example

Date: ____ / ____ / ____ Signature: _____

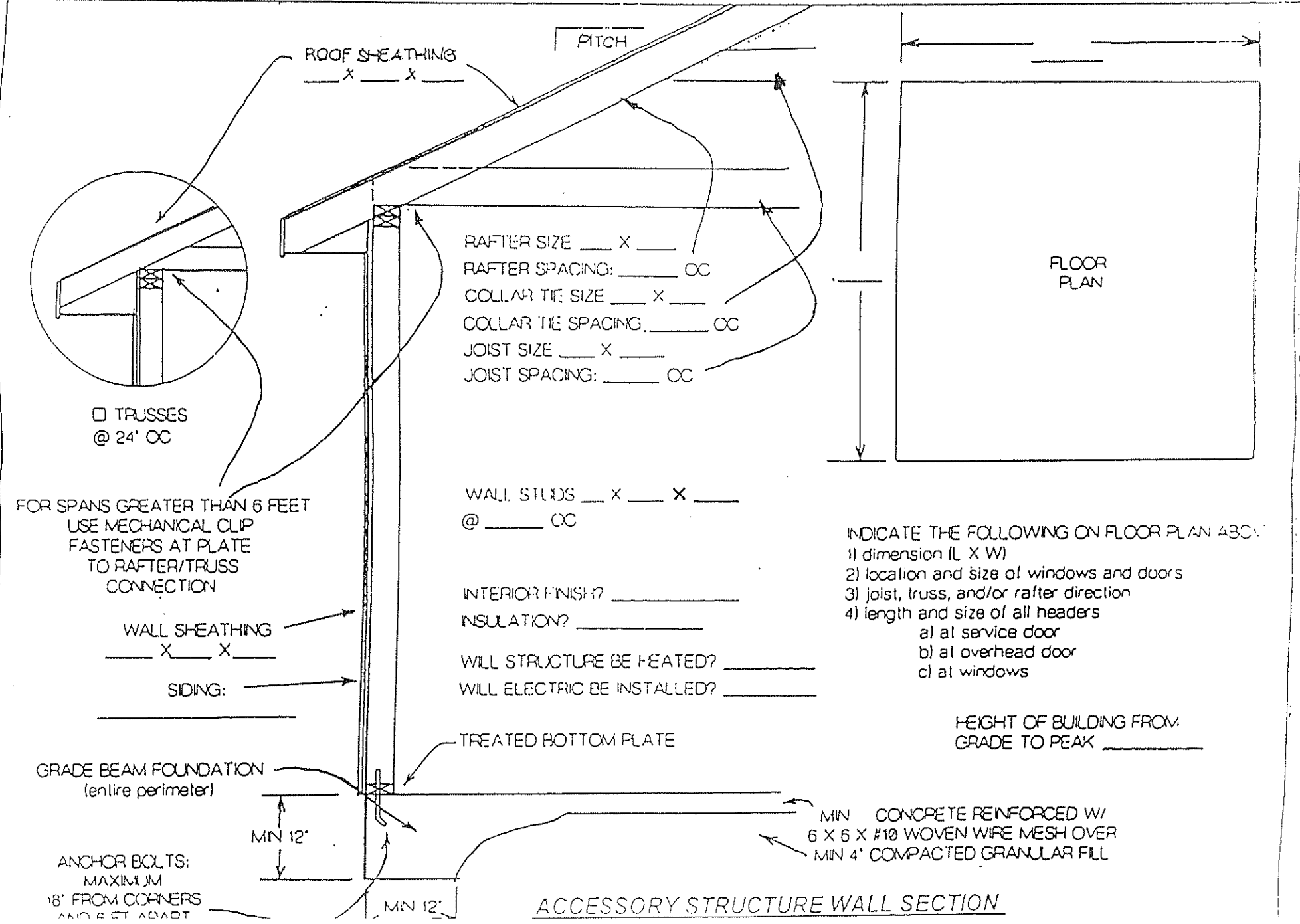

ROOF SHEATHING
___ X ___ X

PITCH

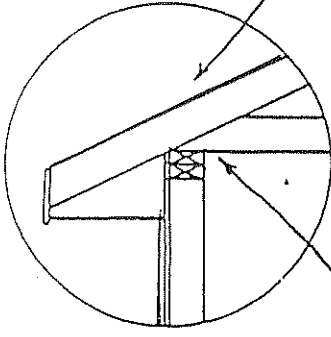

□ TRUSSES
@ 24' OC

RAFTER SIZE ___ X ___
 RAFTER SPACING: ___ OC
 COLLAR TIE SIZE ___ X ___
 COLLAR TIE SPACING: ___ OC
 JOIST SIZE ___ X ___
 JOIST SPACING: ___ OC

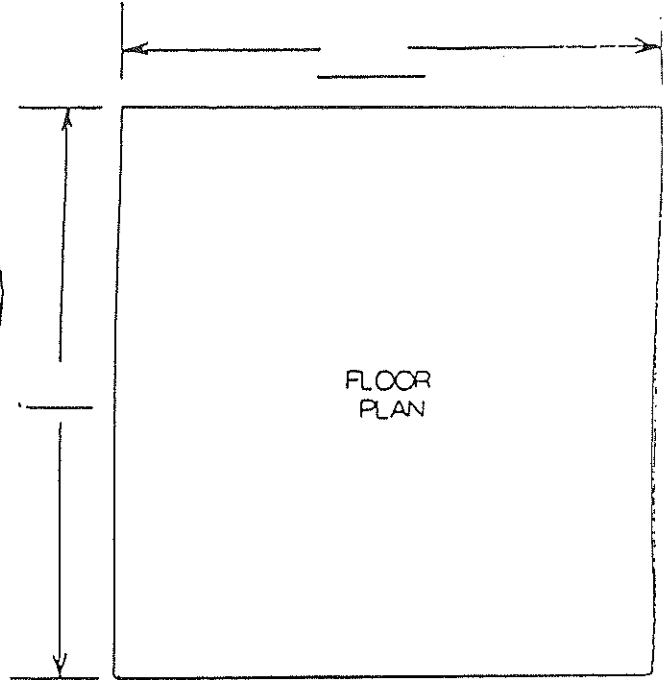

FLOOR PLAN

FOR SPANS GREATER THAN 6 FEET
 USE MECHANICAL CLIP
 FASTENERS AT PLATE
 TO RAFTER/TRUSS
 CONNECTION

WALL SHEATHING
___ X ___ X

SIDING:

WALL STUDS ___ X ___ X
 @ ___ OC

INTERIOR FINISH? _____
 INSULATION? _____

WILL STRUCTURE BE HEATED? _____
 WILL ELECTRIC BE INSTALLED? _____

- INDICATE THE FOLLOWING ON FLOOR PLAN ABOVE:
- 1) dimension (L X W)
 - 2) location and size of windows and doors
 - 3) joist, truss, and/or rafter direction
 - 4) length and size of all headers
 - a) at service door
 - b) at overhead door
 - c) at windows

HEIGHT OF BUILDING FROM
 GRADE TO PEAK _____

GRADE BEAM FOUNDATION
 (entire perimeter)

MIN 12"

MIN 12"

MIN CONCRETE REINFORCED W/
 6 X 6 X #10 WOVEN WIRE MESH OVER
 MIN 4' COMPACTED GRANULAR FILL

ANCHOR BOLTS:
 MAXIMUM
 18' FROM CORNERS
 AND 6 FT APART

TREATED BOTTOM PLATE

ACCESSORY STRUCTURE WALL SECTION

Wisconsin Division of Safety and Buildings		WISCONSIN UNIFORM BUILDING PERMIT APPLICATION					Application No.		
Wisconsin Stats. 101.63, 101.73		Instructions on back of second ply. The information you provide may be used by other government agency programs [(Privacy Law, s. 15.04 (1)(m))]					Parcel No.		
PERMIT REQUESTED		Constr. HVAC Electric Plumbing Erosion Control Other:							
Owner's Name			Mailing Address				Tel.		
Contractor Name & Type			Lic/Cert#	Mailing Address			Tel. & Fax		
Dwelling Contractor (Constr.)									
Dwelling Contr. Qualifier				The Dwelling Contr. Qualifier shall be an owner, CEO, COB or employee of the Dwelling Contr.					
HVAC									
Electrical									
Plumbing									
PROJECT LOCATION		Lot area Sq.ft.	One acre or more of soil will be disturbed		_____ 1/4, _____ 1/4, of Section _____, T _____ N, R _____ E (or) W				
Building Address			Subdivision Name			Lot No.	Block No.		
Zoning District(s)		Zoning Permit No.		Setbacks:	Front ft.	Rear ft.	Left ft.	Right ft.	
1. PROJECT		3. OCCUPANCY		6. ELECTRIC		9. HVAC EQUIP.		12. ENERGY SOURCE	
New Alteration Addition Other:		Repair Raze Move		Single Family Two Family Garage Other:		Entrance Panel Amps: _____ Underground Overhead		Furnace Radiant Basebd Heat Pump Boiler Central AC	
				7.WALLS		□ Fireplace Other:		Fuel Nat Gas LP Oil Elec Solid Solar	
				Wood Frame Steel				Space Htg □ □ □ □ □ □	
				□ ICF □ Timber/Pole □ Other:				Water Htg □ □ □ □ □ □	
2. AREA INVOLVED (sq ft)		4. CONST. TYPE		8. USE		10. SEWER		13. HEAT LOSS	
Unit 1 Unit 2 Total		Site-Built Mfd. per WI UDC Mfd. per US HUD		Seasonal Permanent Other:		Municipal Sanitary Permit# _____		_____ BTU/HR Total Calculated Envelope and Infiltration Losses ("Maximum Allowable Heating Equipment Output" on Energy Worksheet; "Total Building Heating Load" on Rescheck report)	
Unfin. Bsmt									
Living Area									
Garage		1-Story							
Deck		2-Story							
Totals		Other: Plus Basement				11. WATER		14. EST. BUILDING COST w/o LAND	
						Municipal On-Site Well		\$	
I understand that I am subject to all applicable codes, statutes and ordinances and with the conditions of this permit; understand that the issuance of the permit creates no legal liability, express or implied, on the state or municipality; and certify that all the above information is accurate. If one acre or more of soil will be disturbed, I understand that this project is subject to ch. NR 151 regarding additional erosion control and stormwater management and the owner shall sign the statement on the back of the permit if not signing below. I expressly grant the building inspector, or the inspector's authorized agent, permission to enter the premises for which this permit is sought at all reasonable hours and for any proper purpose to inspect the work which is being done.									
I vouch that I am or will be an owner-occupant of this dwelling for which I am applying for an erosion control or construction permit without a Dwelling Contractor Certification and have read the cautionary statement regarding contractor responsibility on the reverse side of the last ply.									
APPLICANT (Print:) _____			Sign: _____				DATE _____		
APPROVAL CONDITIONS		This permit is issued pursuant to the following conditions. Failure to comply may result in suspension or revocation of this permit or other penalty. See attached for conditions of approval.							
ISSUING JURISDICTION		Town of	Village of	City of	County of	State→	State-Contracted Inspection Agency#:		Municipality Number of Dwelling Location _____ - _____
FEES:		PERMIT(S) ISSUED		WIS PERMIT SEAL #		PERMIT ISSUED BY:			
Plan Review \$ _____		Construction				Name _____			
Inspection \$ _____		HVAC				Date _____ Tel. _____			
Wis. Permit Seal \$ _____		Electrical				Cert No. _____			
Other \$ _____		Plumbing							
Total \$ _____		Erosion Control							

INSTRUCTIONS

The owner, builder or agents shall complete the application form down through the Signature of Applicant block and submit it and building plans and specifications to the enforcing municipality. Permit application data is used for statewide statistical gathering on new one- and two-family dwellings, as well as for local code administration. **Please type or use ink and press firmly with multi-ply form.**

PERMIT REQUESTED

- Check off type of Permit Requested, such as structural, HVAC, Electrical or Plumbing.
- Fill in owner's current Mailing Address and Telephone Number.
- If the project will disturb one acre or more of soil, the project is subject to the additional erosion control and stormwater provisions of ch. NR 151 of the WI Administrative Code. Checking this box will satisfy the related notification requirements of ch. NR 216.
- Fill in Contractor and Contractor Qualifier Information. Per s. 101.654 (1) WI Stats., an individual taking out an erosion control or construction permit shall enter his or her dwelling contractor certificate number, and name and certificate number of the dwelling contractor qualifier employed by the contractor, unless they reside or will reside in the dwelling. Per s. 101.63 (7) Wis. Stats., the master plumber name and license number must be entered before issuing a plumbing permit.

PROJECT LOCATION

- Fill in Building Address (number and street or sufficient information so that the building inspector can locate the site).
- Local zoning, land use and flood plain requirements must be satisfied before a building permit can be issued. County approval may be necessary.
- Fill in Zoning District, lot area and required building setbacks.

PROJECT DATA - Fill in all numbered project data blocks (1-14) with the required information. All data blocks must be filled in, including the following:

2. Area (involved in project):
 - Basements - include unfinished area only
 - Living area - include any finished area including finished areas in basements
 - Two-family dwellings - include separate and total combined areas
3. Occupancy - Check only "Single-Family" or "Two-Family" if that is what is being worked on. In other words, do not check either of these two blocks if only a new detached garage is being built, even if it serves a one or two family dwelling. Instead, check "Garage" and number of stalls. If the project is a community based residential facility serving 3 to 8 residents, it is considered a single-family dwelling.
9. HVAC Equipment - Check only the major source of heat, plus central air conditioning if present. Only check "Radiant Baseboard" if there is no central source of heat.
10. Plumbing - A building permit cannot be issued until a sanitary permit has been issued for any new or affected existing private onsite wastewater treatment system.
14. Estimated Cost - Include the total cost of construction, including materials and market rate labor, but not the cost of land or landscaping.

SIGNATURE - Sign and date this application form. If you do not possess the Dwelling Contractor certification, then you will need to check the owner-occupancy statement for any erosion control or construction permits.

CONDITIONS OF APPROVAL - The authority having jurisdiction uses this section to state any conditions that must be complied with pursuant to issuing the building permit.

ISSUING JURISDICTION: This must be completed by the authority having jurisdiction.

- Check off Jurisdiction Status, such as town, village, city, county or state and fill in Municipality Name
- Fill in State Inspection Agency number only if working under state inspection jurisdiction.
- Fill in Municipality Number of Dwelling Location
- Check off type of Permit Issued, such as construction, HVAC, electrical or plumbing.
- Fill in Wisconsin Uniform Permit Seal Number, if project is a new one- or two-family dwelling.
- Fill in Name and Inspector Certification Number of person reviewing building plans and date building permit issued.

PLEASE RETURN SECOND PLY WITHIN 30 DAYS AFTER ISSUANCE TO (You may fold along the dashed lines and insert this form into a window envelope.):

Safety & Buildings Division
P O Box 2509
Madison, WI 53701-2509

Cautionary Statement To Owners Obtaining Building Permits

101.65(lr) of the Wisconsin Statutes requires municipalities that enforce the Uniform Dwelling Code to provide an owner who applies for a building permit with a statement advising the owner that:

If the owner hires a contractor to perform work under the building permit and the contractor is not bonded or insured as required under Ss. 101.654 (2) (a), the following consequences might occur:

(a) The owner may be held liable for any bodily injury to or death of others or for any damage to the property of others that arises out of the work performed under the building permit or that is caused by any negligence by the contractor that occurs in connection with the work performed under the building permit.

(b) The owner may not be able to collect from the contractor damages for any loss sustained by the owner because of a violation by the contractor of the one and two family dwelling code or an ordinance enacted under Ss. 101.654(1) (a), because of any bodily injury to or death of others or damage to the property of others that arises out of the work performed under the building permit or because of any bodily injury to or death of others or damage to the property of others that is caused by any negligence by the contractor that occurs in connection with the work performed under the building permit.

Additionaly: Wisconsin Statute: 101.6 Compliance and penalties. (1) “Every builder, designer and owner shall use building materials, methods and equipment which are in conformance with the one and two family dwelling code.”

Consequently: If the owner signs the Permit Application, the owner is held responsible for any code violation, Orders for Correction and/or citation(s) that may be issued in association with the Permit.

If a contractor signs the Permit as agent for the owner, the contractor is held responsible for any code violations, Orders for Correction and/or citation(s) that may be issued in association with the Permit.

Owner Signature: _____ Date: ____/____/_____